

TITLE: ATOM MILLENIUM harness-containers 35-1

1. Technical background

a) Effectivity

Type

35-1

Serial Number

JE011 to KB040

- b) Reason** : Hypothesis of hooking of the main central flap by one or several suspension lines having led to the tearing of the aforesaid flap.
- c) Description** : Installation of a deflector aiming to prevent interference between suspension lines and the foresaid flap.
- d) Compliance** : Mandatory.
- e) Approval** :
- f) Man power** : Qualified rigger
- g) Weight and balance** : Non applicable
- h) References** : FEE N° 183 ed 02
- i) Publication affected** : This instruction is an addition to the use and maintenance manual ref 9009113100 edition 08 of 03/99
- j) Interchangeability** : Non applicable

2. Information about the equipment :

Material : Deflector ref : 2007910010 Quantity: 1

Supplier : Parachutes de France SA 2 rue Denis papin Jouy le moutier
95031 Cergy FRANCE

Coast : Free of charge

Availability : Immediate.

3. Accomplishment instructions: According to instructions and drawings (pages 2 & 3).

Deflector parts	Qty
A : 10/10 polyethylene part	1
B : parapack part	1
C : 3/4 inch tape	0.41 m
D : Polyamide 30/3 thread, 6 kg (E-thread)	

Sewing machine :
 1 needle straight point

Manufacturing deflector:

1 fold part B along the axis drawn, coating inside.

Jig for Parapack part

2 Slide plastic part A inside (polyethylene 10/10)

3 Make a basting stitch 5mm from the edges all around (checking all edges match)

4 Bind according to the drawing, making two stitches 5mm apart.

5 Check stitches

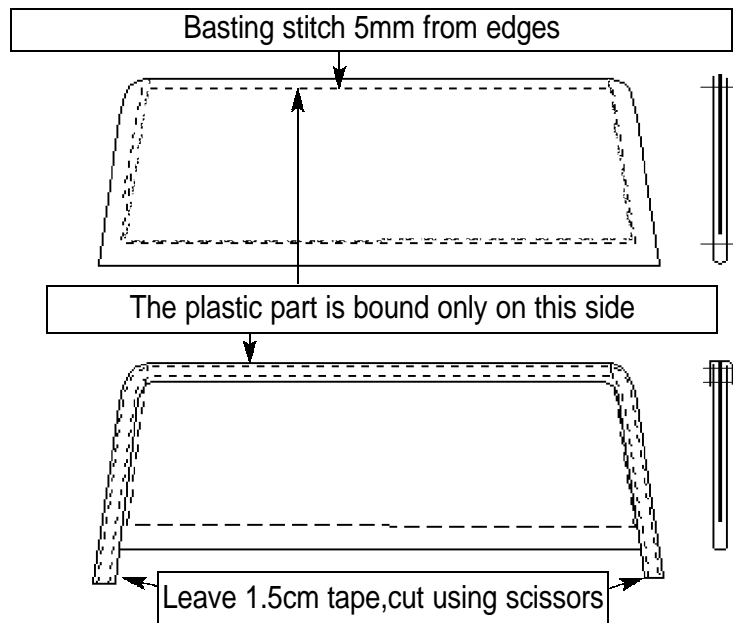
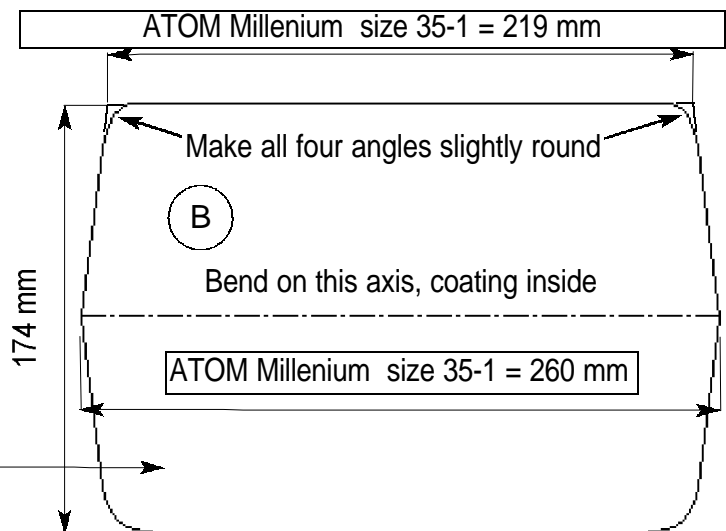
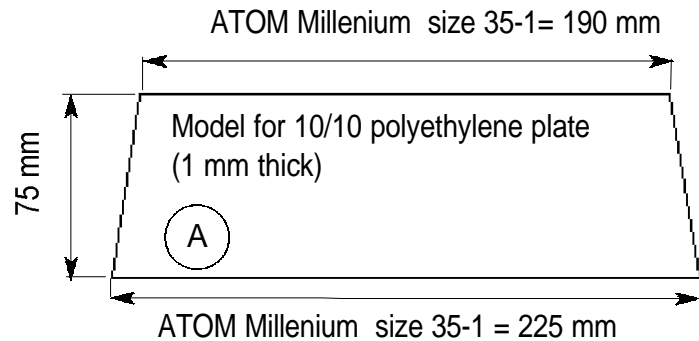

Installation of the deflector flap onto harness container:

- 1 Mark the vertical reserve wall horizontally, 1cm below the upper main flap stitch. This mark must be centered.
- 2 Stitch the deflector flap onto the wall, bending the tape ends underneath. Make two stitches 5mm apart.
- 3 Make a 2cm stop-point back and forth at both ends of each stitch.
- 4 Check the quality of stitches

Type	Size 1
AT35-1	250 mm

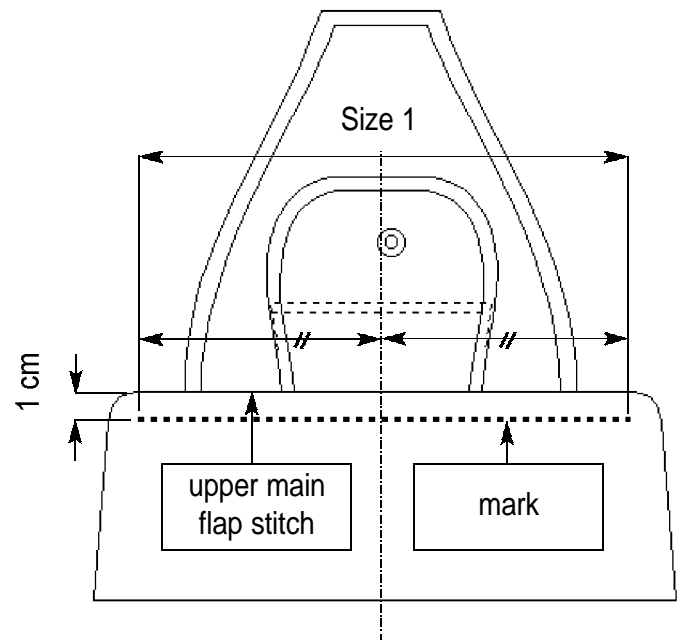

Detail of double stitch with back and forth stop points

Bend the tape under the deflector flap.

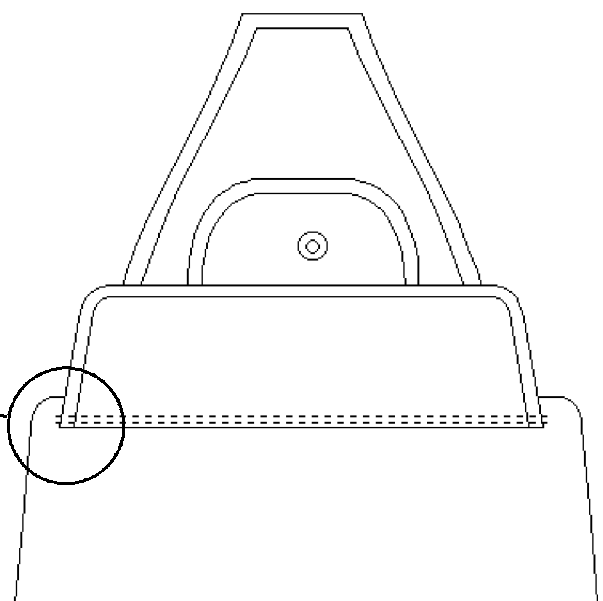
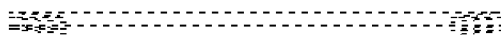
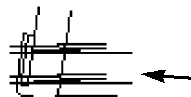

AT 35 - 25 - 001

Make three (3) straight stitch passes.

